

SEE "DETAIL B"

A) "T"=THICKNESS IN SIXTEENTHS. SPECIFY WHEN ORDERING--MIN. THICKNESS IS 1/4" AND MAX. THICKNESS IS 2-1/2".  
EXAMPLE: 128FY0025 IS 1/4" THICK

IF FLANGE RING IS TO BE STACKED OVER SPACER RING (PKG. 17), PLEASE CONSULT BOLT CHART FOR APPROPRIATE BOLT LENGTH AND ORDERING INFORMATION.

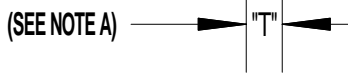

B) FINISH IS HOT DIP GALVANIZE  
ASTM A386 C.1.A

D) L-868 10" NOM. O.D.: OLSON #108FY(T) (SPECIFY THICKNESS IN 1/16")  
L-868 12" NOM. O.D.: OLSON #128FY(T) (SPECIFY THICKNESS IN 1/16")

C) (6) 3/8-16" X "T" + 1-1/4" LONG STAINLESS STEEL BOLTS, CEC LOCKWASHERS AND "O" RING GASKET SHIPPED WITH L-868 FLANGE RING.

	NOM. DIA.	"AA"	"BB"	"CC"	"HH"
L-868A	10"	10.160	9.250	8.000	8.145
L-868B	12"	12.160	11.250	10.000	10.145
L-868C	15"	15.160	14.250	13.000	13.145

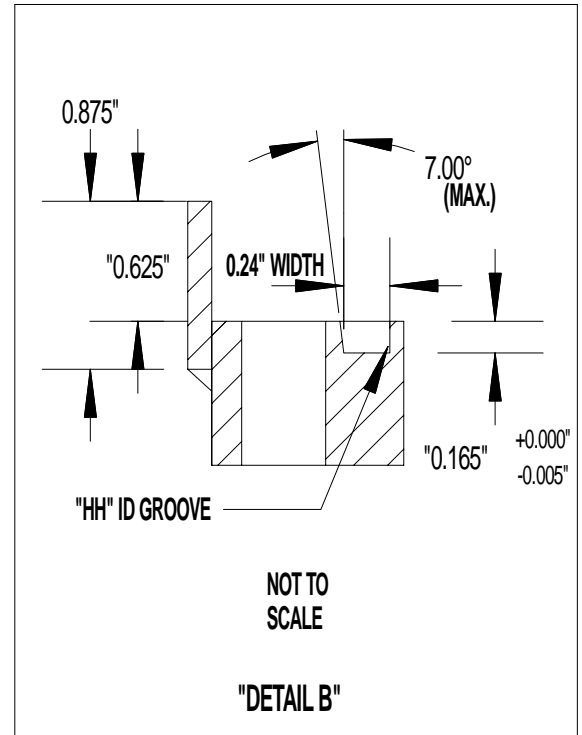

NOT TO SCALE

"DETAIL B"

UD 03/06/00  
Min. "T" Chg./OD Tol U. 4/30/01

DRAWN BY: TOJ/MR	TITLE: L-868 FLANGE RING WITH PAVEMENT RING	<b>OLSON INDUSTRIES, INC.</b> ATKINSON, NE 68713 PKG. NO.: 18.1 MODEL NO.: 8FY PART NO.: SEE NOTES
APPR. BY: TOJ	MAT. SPEC.: STEEL, 30,000 PSI YIELD STRENGTH	
DATE: 11/19/1996	NEXT ASSEM. IS: -----	
SCALE: 4:1	UNLESS OTHERWISE SPECIFIED DIMENSIONS ARE IN INCHES	
FILE NAME: 108128158FY	FRACTIONS ± 1/32" DECIMALS ± 0.030" ANGLES ± 0.5 Deg.	