

(6) 7/16" HOLES
EQUALLY SPACED

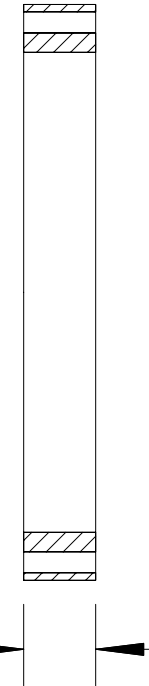
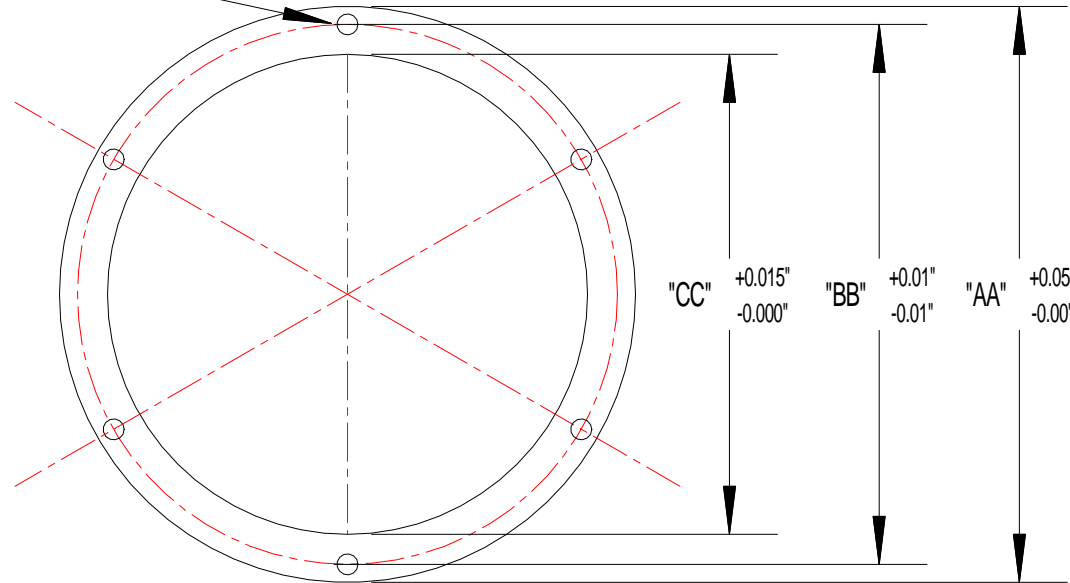

"T" →
0.062" MIN.
2.500" MAX.
(SEE NOTE A)

NOTES:

- A) "T"=THICKNESS IN SIXTEENTHS. SPECIFY WHEN ORDERING.
- B) FINISH IS HOT DIP GALVANIZE, ASTM A386, C1.A
- C) (6) 3/8-16" X "T" + 1-1/4" LONG STAINLESS STEEL BOLTS SHIPPED WITH L-868 SPACER RING.

- D) L-868 10" NOM. O.D.: OLSON #108S(T) (SPECIFY THICKNESS IN 1/16")
- L-868 12" NOM. O.D.: OLSON #128S(T) (SPECIFY THICKNESS IN 1/16")
- L-868 15" NOM. O.D.: OLSON #158S(T) (SPECIFY THICKNESS IN 1/16")
- EX: 128S0075 - 3/4" THICKNESS

IF SPACER RING IS TO BE STACKED UNDER FLANGE RING (PKG. 18.0 OR 18.1) PLEASE CONSULT BOLT CHART FOR APPROPRIATE BOLT LENGTH AND ORDERING INFORMATION.

	NOM. DIA.	"AA"	"BB"	"CC"
L-868A	10"	10.000	9.250	8.000
L-868B	12"	12.000	11.250	10.000
L-868C	15"	15.000	14.250	13.000

UD 04/30/01 - ID Tol. Up. UD 04/06/02	DRAWN BY: TOJ/VR	TITLE: L-868 SPACER RING	OLSON INDUSTRIES, INC. ATKINSON, NE 68713 PKG. NO.: 17.0 MODEL NO.: 8S PART NO.: SEE NOTE D ABOVE
	APPR. BY: TOJ	MAT. SPEC.: -----	
	DATE: 11/07/1996	NEXT ASSEM. IS: -----	
	SCALE: 4:1	UNLESS OTHERWISE SPECIFIED DIMENSIONS ARE IN INCHES	
	FILE NAME: 128158S	FRACTIONS ± 1/32" DECIMALS ± 0.030" ANGLES ± 0.5 Deg.	